

# Assembly Instructions

## Accelerometer BA...



ConSenses GmbH

Arheilger Weg 11  
D-64380 Roßdorf  
Germany

E-mail: [info@consenses.de](mailto:info@consenses.de)

ConSenses 2019. All rights reserved



The national and local regulations for environmental protection and raw material reclamation must be considered when disposing of accelerometers that are no longer serviceable. Please dispose of separately from regular household waste. For further information on disposal, please contact the local authorities or the dealer where you purchased the product.

The information presented in this document reflects the current state of knowledge. ConSenses reserves the right to make technical changes. Liability for consequential damages resulting from the use of ConSenses products is excluded.

**ConSenses** is a registered trademark of ConSenses GmbH.

The contents of this document may not be reproduced, transmitted, distributed or stored in any form, in whole or in part, without the written permission of ConSenses.

## Content

1.	Scope of delivery and Accessories .....	1
2.	Operating Principle and Application Notes.....	2
3.	Safety Instructions.....	4
3.1.	Intended Use.....	4
3.2.	Operating Personnel.....	4
3.3.	Safety Regulations and Load Limits .....	4
3.4.	Supplementary Safety Precautions .....	5
3.5.	General Hazards due to Non-observance of the Safety Instructions.....	5
3.6.	Modifications and Change.....	5
4.	Conditions and Preparations on Site .....	6
5.	Mechanical Installation.....	7
5.1.	General Installation Guidelines.....	7
5.2.	Installation.....	7
6.	Connection.....	8
7.	Technical Data.....	9
7.1.	Dimensions.....	9
7.2.	Series-specific Data.....	9
7.3.	General Data .....	9
8.	Declaration of Conformity.....	10

Failure to observe safety instructions may result in damage to persons or the machine. Therefore, please observe the safety instructions before each use.

If you have any questions about this product, please contact the manufacturer:

ConSenses GmbH, Arheilger Weg 11, D-64380 Roßdorf, Germany  
E-mail: [info@consenses.de](mailto:info@consenses.de)



## 1. Scope of delivery and Accessories

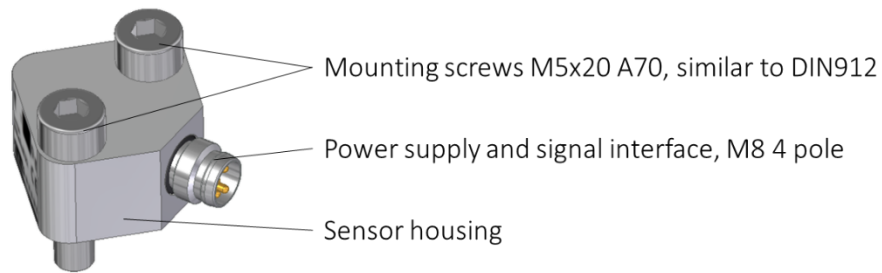

### Labeling:

Positive measuring direction

Serial number

Manufacturer logo

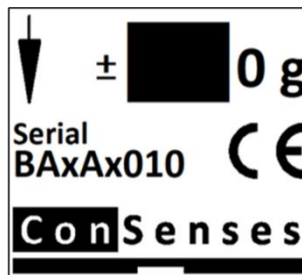

Measuring range

CE marking

The plug connection on the accelerometer is detachable. Different measuring ranges are available under the following order numbers:

Order number	Description
03.90203	Accelerometer BA with measuring range $\pm 50$ g
03.90204	Accelerometer BA with measuring range $\pm 100$ g
03.90205	Accelerometer BA with measuring range $\pm 200$ g
03.90206	Accelerometer BA with measuring range $\pm 500$ g

Suitable signal cables in various lengths, as well as solutions for cable routing on moving assemblies, are available on request.

## 2. Operating Principle and Application Notes

The accelerometer's sensor is MEMS-based. MEMS stands for "Micro-Electro-Mechanical Systems". In this case, the measurement principle is capacitive and offers the following advantages:

- ✓ The basic sensor system (in contrast to piezo-based acceleration sensors) do not represent an uncontrollable source of energy in the limit range. Thus, the system is very quickly ready for measurements again - even in the event of unexpected shocks (within 500  $\mu$ s)
- ✓ Static measurements are possible, i.e., frequencies starting from 0 Hz can be evaluated.
- ✓ No additional measuring amplifier is required

The basic MEMS sensor is electrically installed into the accelerometer as follows:

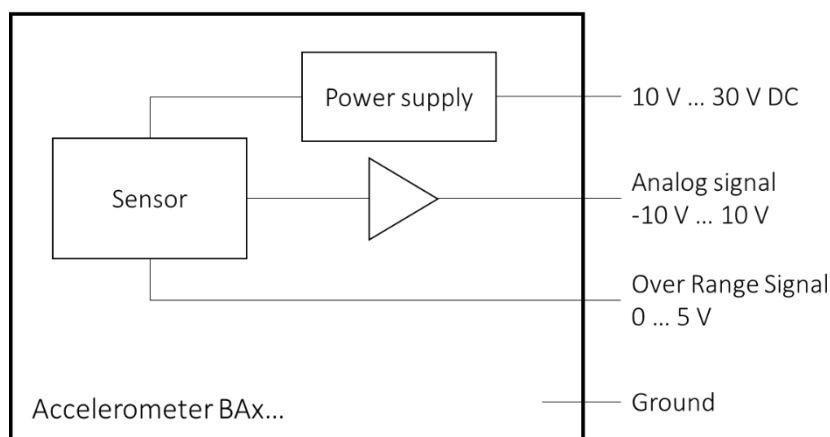

Figure 1: Block diagram

Under overload, for example, an accelerometer with a measuring range of  $\pm 50$  g exhibits the following signal behavior:

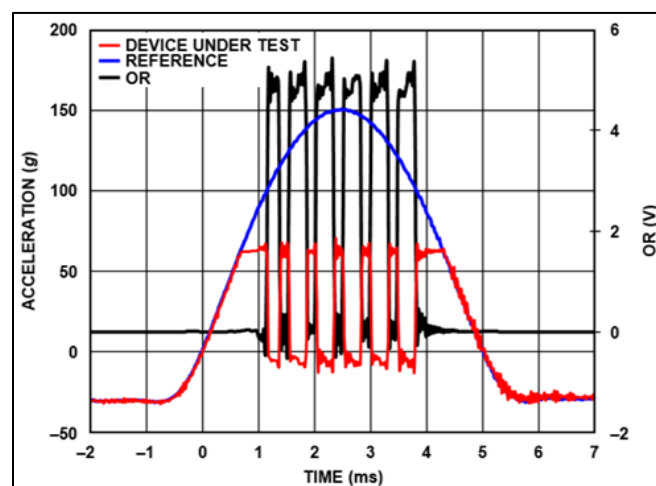

Figure 2: Signal behavior under overload (source: Analog Devices)

As can be seen in Figure 2, the output signal (red, -40...60 g) follows the acceleration load (blue, -40...150 g) until the measuring range limit is reached. The output signal is limited by the supply voltage and does not increase further when the load is increased. Approximately 0.5 ms after exceeding the measuring range

limit, the over-range output (black, 0...5 V) signals for 0.5 ms that the measuring range has been exceeded. The MEMS sensor then checks whether operation is within the measuring range limits. In the figure, this is not the case again until a few 0.5 ms cycles later, whereupon the sensor registers the correct values again within a 0.5 ms cycle.

When using the product, please consider the

- Maximum load limits
- Safety factors from special safety regulations (e.g., EX areas, regulations for personal and plant protection)
- Environmental conditions.

Also observe the following safety instructions and installation guidelines.

## 3. Safety Instructions

### 3.1. Intended Use

The accelerometers BA are sensors for the metrological detection of vibrations on components or machine elements within the operating limits of the sensor.

Any other use is not in accordance with the intended use.

To ensure safe operation, the product may only be used in accordance with the information in these assembly instructions and in compliance with the following safety regulations and the technical data provided. During use, the legal and safety regulations required for the respective application must also be observed. This also applies analogously to the use of accessories.

The accelerometers are not intended for use as safety components. Proper transport, professional storage and assembly as well as careful operation and maintenance are prerequisites for faultless and safe operation of the accelerometers.

### 3.2. Operating Personnel

This product must be installed and operated exclusively by qualified personnel in accordance with the technical data in connection with the safety provisions and regulations set out below.

Qualified personnel include persons who, as operators of the equipment under investigation, have been instructed in its handling and safety concepts and are familiar with the operation of the product described in this documentation. They must have read and understood the assembly instructions and the safety instructions carefully.

When using the accelerators, the legal and safety regulations required for the respective application must also be observed. This also applies analogously to the use of accessories.

Ensure that work is carried out in a safety-conscious manner and compliance with the relevant accident prevention regulations, e.g., those of the employers' liability insurance associations.

### 3.3. Safety Regulations and Load Limits

For safe operation of the product, it is essential to observe the assembly instructions and load limits. The maximum loads specified in the technical data sheets must not be exceeded under any circumstances. This concerns:

- Maximum shock acceleration
- Temperature limits

Signal cables of the sensors must be installed in such a way that electromagnetic emissions do not impair the sensor function.

Prior to each commissioning, project planning and risk analysis must be carried out, considering all safety aspects of the surrounding technology. In particular, this concerns personal and plant protection. Supplementary safety precautions must be taken to prevent defects or faults in equipment that could result in personal injury, equipment damage, or loss of data.



### 3.4. Supplementary Safety Precautions

As passive sensors, accelerometers cannot perform any safety-relevant functions. This requires additional components and equipment for which the installer and operator are responsible. Electronics that process such a measurement signal must be designed in such a way that no consequential damage can occur if a measurement signal fails.

In the event of a fault, in which persons or property may be harmed by loosening or malfunctioning of the product, the user must take precautions to ensure a safe operating state. Such precautions can be implemented, for example, by means of separating or non-separating protective devices or the like and must at least meet the requirements of the relevant accident prevention regulations.

### 3.5. General Hazards due to Non-observance of the Safety Instructions

The accelerometers correspond to the state of the art and are operationally safe. There are residual risks associated with improper use. For this reason, every person who is entrusted with the installation, commissioning, and dismantling of the sensor must read and understand the operating instructions and, in particular, the safety instructions.

Improper use of the accelerometer or failure to observe the safety regulations can result in damage, malfunction, failure, or loosening of the accelerometer. In particular, loosening the accelerometer can cause damage to property or persons in the vicinity of the accelerometer.

The scope of services and delivery of the product covers an accelerometer up to the standardized connection and is only part of the measurement chain. Safety-related aspects of the measuring chain must also be planned, implemented, and accounted for by the system planner/supplier/operator in such a way that residual risks are minimized and identified. Existing regulations must be observed.

### 3.6. Modifications and Change

The product must not be modified without the express consent of the manufacturer. Any change excludes the manufacturer's liability for any resulting damage.

## 4. Conditions and Preparations on Site

Ensure that the accelerometers BA are protected from adverse conditions such as salt water, snow, rain, or ice.

Protect the contact points from contamination and do not touch the terminals.

A constant temperature within the operating range affects the sensitivity of the accelerometers only to a small extent.

You should avoid using the accelerometer in extreme humidity (>90 % relative humidity, or thawing atmosphere). Accelerometers with connected signal cable have protection class IP67 according to DIN EN 60529. This protection class is only guaranteed if the connector is properly mounted on the accelerometer.

The accelerometer is made of stainless steel. Ensure that the accelerometers do not come into contact with chemicals that can attack the surface. Protect the signal cable from aggressive chemicals. Acids and other corrosive substances release ions that can cause the accelerometer to fail. In this case, please initiate appropriate protective measures.

Note: Contaminated, painted or damaged screw connection points prevent sustainable mounting of the accelerometers. Ensure that the installation location is level to allow the sensor to be mounted flat.

## 5. Mechanical Installation

### 5.1. General Installation Guidelines

Handle the accelerometers gently. You thus prevent damage that can impair the mounting of the accelerometer or signal cable as well as the measurement signal. The signal interface connection should be easily accessible.

Make sure that the accelerometer is not overloaded. In the event of an overload, there is a risk of damage or loosening, resulting in hazards for operating personnel and equipment. Take appropriate measures to protect against overload or to safeguard against the consequences of loosening.

### 5.2. Installation

The accelerometers can be attached to the specimen using the supplied M5x20 cap screws of grade A2 or A4 according to ISO 4762/similar to DIN 912. The tightening torque is between 4 and 6 Nm, depending on the thread and friction conditions.

During assembly, make sure that the accelerometer is not overloaded.

## 6. Connection

Screw the data cable onto the accelerometer by hand and avoid using tools. Make sure that the connection point is easily accessible.

Please pay attention to the following pin assignment of the connection cable:

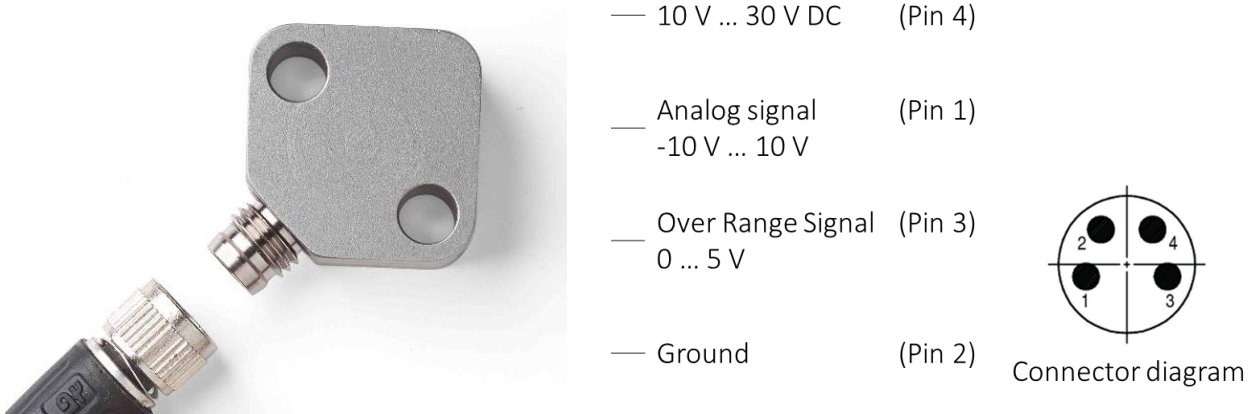

If you obtain cables from ConSenses original accessories, the following specifications apply to the shielded connection cable with open ends:

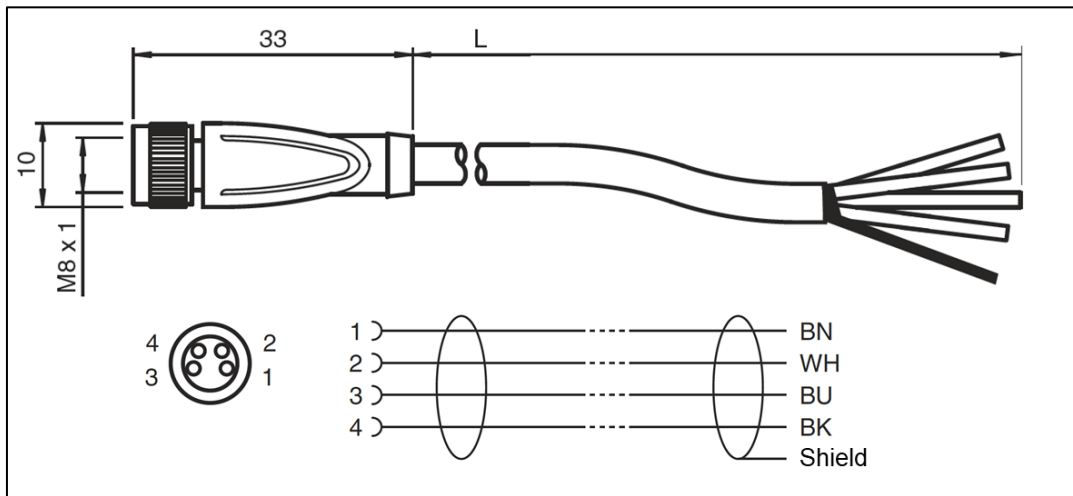

When laying the cable, make sure that the cable is moved as little as possible and preferably rests. The minimum cable bending radius is 45 mm.

Avoid stray fields from motors, transformers, and contactors. Do not lay signal cables in the immediate vicinity of power lines or on hot parts.

## 7. Technical Data

### 7.1. Dimensions

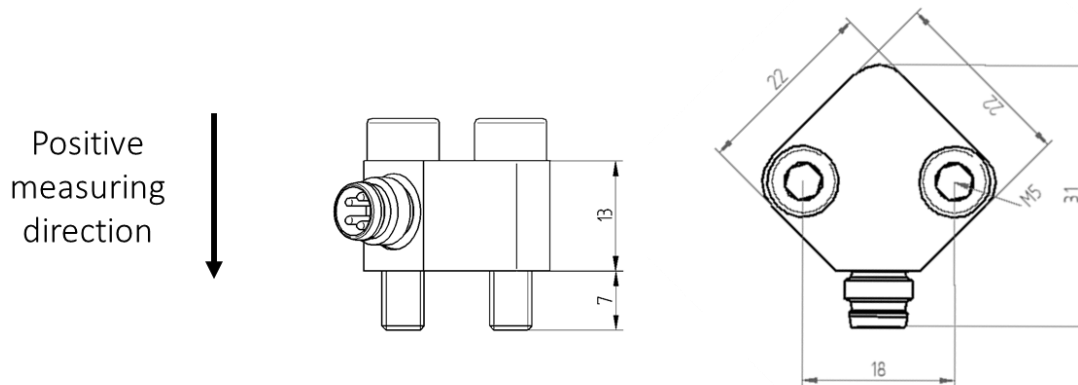

The two through holes for the fastening screws have a diameter of 5.5 mm.

### 7.2. Series-specific Data

Measuring range	g	± 50	± 100	± 200	± 500
Sensitivity	mV/g	200	100	50	20

### 7.3. General Data

Operating temperature range	°C	-20 ... 70
Protection class according to DIN EN 60529 (with cable connected)		IP67
Linear frequency range	kHz	0 ... 11
Overload recovery time	µs	500
Shock resistance	g	10,000
Supply voltage	V	DC 10 ... 30, recommended: 12
Output voltage	V	-10 ... 10
Weight	g	31

## 8. Declaration of Conformity



We,

**ConSenses GmbH, Arheilger Weg 11, D-64380 Roßdorf, Germany**

declare under our sole responsibility that the product

**Accelerometer**

in the versions

**BA...**

complies with the following provision of the European Union:

*Directive 2014/30/EU of the European Parliament and of the Council of 26 February 2014 on the harmonization of the laws of the Member States relating to electromagnetic compatibility*

The relevant standards or normative documents used as a basis are listed below:

*EN 61326-1: 2013 Electrical equipment for measurement, control and laboratory use – EMC requirements – Part 1: General requirements*

*EN 61326-2-3:2013 Electrical equipment for measurement, control and laboratory use – EMC requirements – Part 2-3 Particular requirements – Test configuration, operational conditions and performance criteria for transducers with integrated or remote signal conditioning*

Signed for and on behalf of:

**ConSenses GmbH**

Rossdorf, dated 05/30/2019

A handwritten signature in black ink, appearing to read 'M. Brenneis', is located below the date. The signature is written in a cursive style.

Dr. Matthias Brenneis, Managing Director